



PRÉ-LIMPEZA

PRE-CLEANER

PNH





CARACTERÍSTICAS TÉCNICAS

TECHNIAL FEATURES

FUNCIONAMENTO

OPERATION

O sistema de pré-limpeza ou limpeza funciona com sistema de recirculação de ar e peneiramento

The Pre-Cleaner or cleaner system works with air recirculation and screening systems.

ALIMENTAÇÃO

INLET

Distribuídos de carga, com contrapeso (regulagem), para distribuição uniforme do produto.

Distributed load, with counterweight (setting) for uniform distribution of the product.

OPÇÃO

OPTIONS

Para vários tipos de grãos (milho, feijão, soja, trigo, etc).

For various types of grain (corn, beans, soybeans, wheat, etc).

QUADRO DE PENEIRAS

SCREEN SET

Troca rápida e fácil.
Easy-change screen.

RECIRCULAÇÃO DE AR

AIR RECIRCULATION

O sistema de aspiração com recirculação funciona através de exaustores para retirar impurezas leves (palha e cascas leves).

A aspiração ocorre antes e depois do peneiramento.

The recirculation suction system works through exhaust fans to remove light impurities (straw and light peels). Aspiration occurs before and after screening.

PENEIRAMENTO

SCREENING

Caixa de jogo por excêntrico com peneiras, calibradas de acordo com os grãos a processar (Retira palha grossa, sabugos, cascas, terra e outros corpos estranhos).

Set box by eccentric with screens, calibrated according to the grain processing (Remove thick straw, cobs, husks, dirt and other foreign bodies).

COMPOSIÇÃO

COMPOSITION

Estrutura metálica em aço carbono SAE 1020 e ASTM A36;

Carbon Steel Metal Frame SAE 1020 and ASTM A36;

Acionamento por motor WEG W22 IP55;

Activation by WEG W22 IP55 engine;

Pintura em tinta líquida WEG;

Weg liquid paint;

MODELO <i>Model</i>	PNH 250	PNH 400
CAPACIDADE <i>Capacity</i> (sacos/h) (bags/h)	120 a 150	200 a 400
POTÊNCIA <i>Power</i> (Motores Trif. 220/380 V) (Three-Phase Motors 220/380 V)	1.5 cv 7.5 cv	3.0 cv 7.5 cv
TURBINA <i>Turbine</i>	1 -Dupla <i>1 - Dual</i>	Dupla maior <i>Dual large</i>
PESO <i>Weight</i>	886 Kg	1.540 Kg

*OBS: Produção depende do peso específico do grão
**OBS: Production depends on the specific weight of the grain*



PNH 250

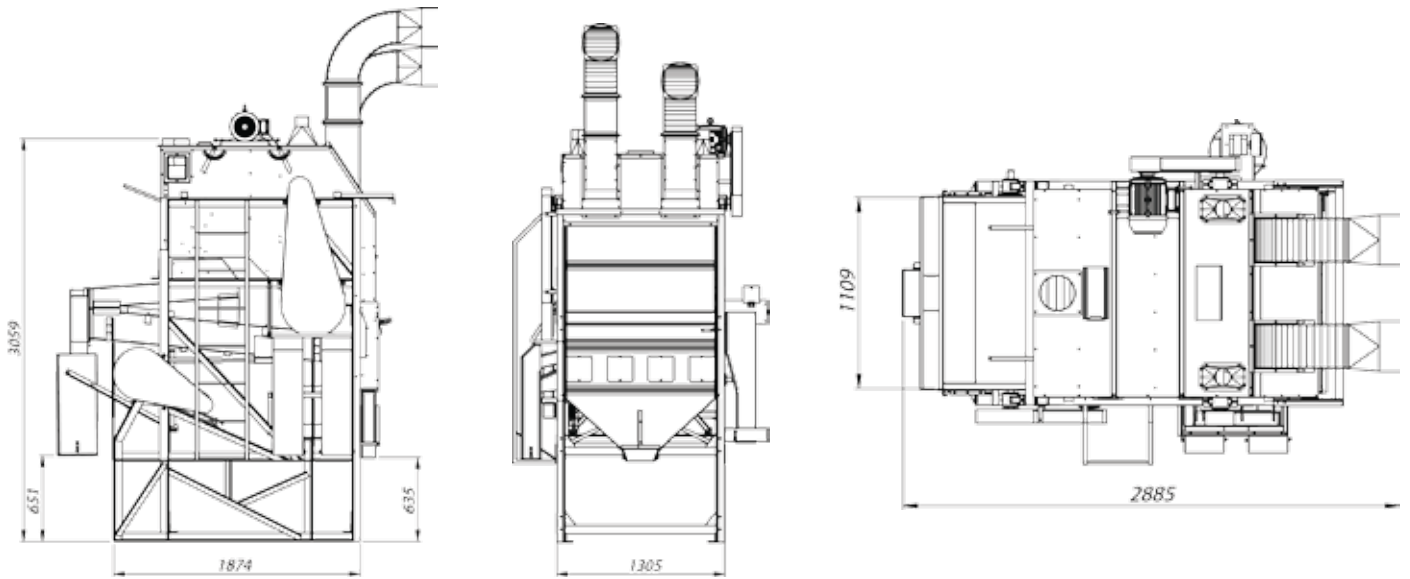

PNH 400

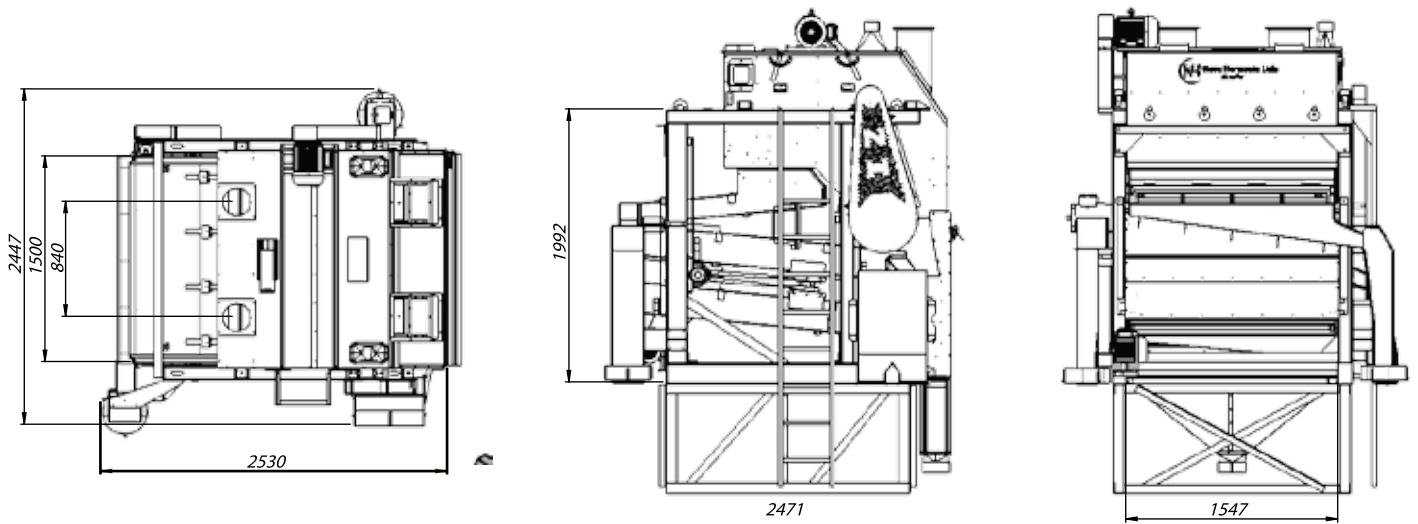

Aceitamos



Consulte-nos



Av. Dorival Faveri, 214 - Graminha
13481-604 - Limeira - SP
Fone: (19) 3451-2822
novo.horizonte@nh.ind.br

